

TABLETSAFE 360™

FULL INSPECTION FOR CAPSULES AND OBLONG TABLETS



TabletSafe 360 is an inspection system purpose-built for pharmaceutical and nutraceutical manufacturers. It delivers full inspection of capsules, oblong tablets, soft-gel and gel-tabs, accurately detecting critical defects in real time—without disrupting your packaging lines.

A dedicated **second inspection stage** verifies the proper ejection of non-conforming units for reliable reject management.

WHY TABLESAFE 360?

Comprehensive inspection, unit by unit: evaluates size, color, coating, print, and physical integrity to help you maintain consistent, compliant quality.

Automates what used to be manual: Replaces labor-intensive checks to cut inspection time and catch issues earlier, driving fast payback at a market-leading price point.

PRODUCTION-READY HARDWARE INCLUDED

- Integrated electrical cabinet
- Enclosed vision head
- Feeder mechanism for stable, consistent product handling
- Motor control with precise adjustments for conveyance speed, roller spin, and speed ramping
- **Second inspection stage** to confirm the proper ejection of non-conforming units
- Dust-tight reject bin for clean, compliant handling
- GMP-compliant, washable design
- Small and long roller options for different formats

SYSTEM FEATURES AND CAPABILITIES

Engineered for flexibility, performance, and quick deployment, **TabletSafe 360** operates entirely offline, making it ideal for facilities seeking powerful inspection without line modifications.

Product Types

Capsules, Oblong Tablets, soft-gel, gel-tabs

Supported Capsule Sizes

00, 0, 1, 2, 3

Inspection Parameters

- ✓ Product size and shape conformity
- ✓ Color consistency and contrast
- ✓ Print presence
- ✓ Dents (lid and body) - Chips on tablet surfaces
- ✓ Splits or broken capsules - Missing coating
- ✓ Tuck defects

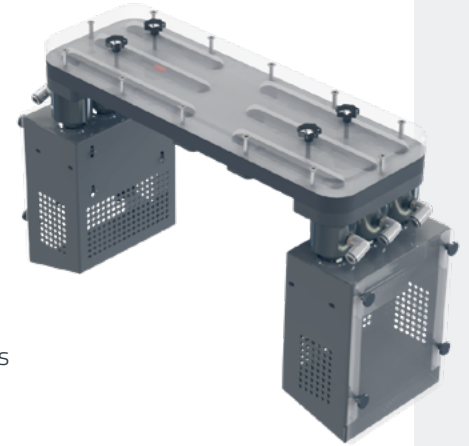

ABOUT OPTEL

For more than 35 years, OPTEL Group has been a global leader in developing Track-and-Trace solutions. Our expertise includes **serialization, aggregation, and AI-powered vision systems.**



Contact your account executive or reach us via our website to book a meeting and reserve your TabletSafe 360 today.



optelgroup.com

©Optel Vision inc. d.b.a. "OPTEL Group", 2025. All rights reserved.