

COUNTSAFE™

ELECTRONIC COUNTERS

**AUTOMATED INSPECTION SYSTEM
DELIVERING SUPERIOR ACCURACY AND EFFICIENCY**



PHARMA



OTHER

OPTEL's **CountSafe™ – Electronic Counters** with automatic ejection significantly reduces the risk of cross-contamination on your bottle filling line, thus reducing the risk of customer complaints and recalls. This high-performance, cost-effective inspection and rejection system provides electronic counter machines with superior inspection accuracy and efficiency. This ergonomically designed solution can be installed on any manufactured electronic counter machine or on an existing line. **CountSafe™ – Electronic Counters** with automatic ejection works for tablets, capsules and softgels of sizes from 4 to 30 mm.

With this system, all products are verified just before falling into the bottles. Once a defect has been detected, the product gets rejected through a vacuum system, attached to a closed bin equipped with a HEPA filter and a pre-separator collector, preventing any substance or dust to escape. As with all OPTEL products, **CountSafe™ – Electronic Counters** follows cGMP guidelines and is FDA 21 CFR Part 11 compliant.

KEY FEATURES

- 100% inspection and ejection for:
 - Wrong color
 - Wrong size
 - Wrong shape
 - Broken or rogue
- 100% good products bottled, no rework
- Complete WGMP design
- Integrated vacuum system with HEPA filter and pre-separator collector

BENEFITS

- Can be integrated into any electronic counter on the market
- Very sharp image and precise analysis
- Fully automatic rejection in less than 5 seconds
- High accuracy with low false-reject rate

COUNTSAFE™ – ELECTRONIC COUNTERS

VISION PERFORMANCE

- Linear speed of up to 200 mm/sec
- False reading prevention (smart threshold)
- Size, length, color and broken detection
- Color differentiation algorithm in CIELAB
- Polarized bright-white LED lighting for a very sharp image and precise analysis
- Product length variation detection $\geq 10\%$
- 100% ejection confirmation

PRODUCT SPECIFICATIONS

Tablets, capsules and softgels with sizes from 4 to 30 mm

EJECTION PERFORMANCE

- Toolless changeovers
- Nozzle adaptable to product size
- Multi-unit coupling capability
- Product pick-up accuracy of ± 0.02 mm of repeatability
- Variable vacuum pressure based on product size
- Dust management system using Nilfisk stainless steel



SHAPE ERROR



COLOR ERROR



BROKEN ERROR

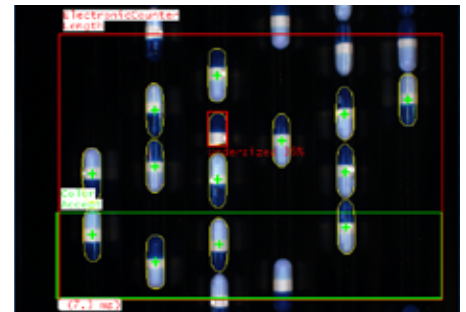

UNDERSIZED ERROR

FRONT VIEW

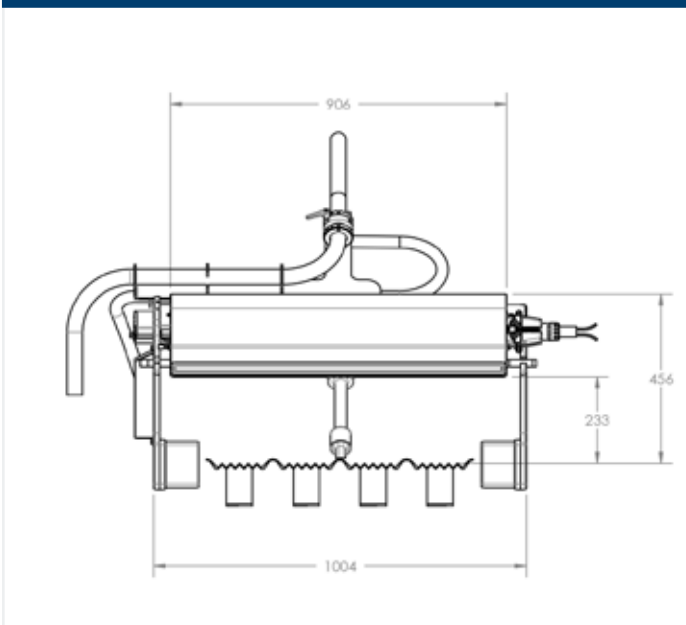

SIDE VIEW

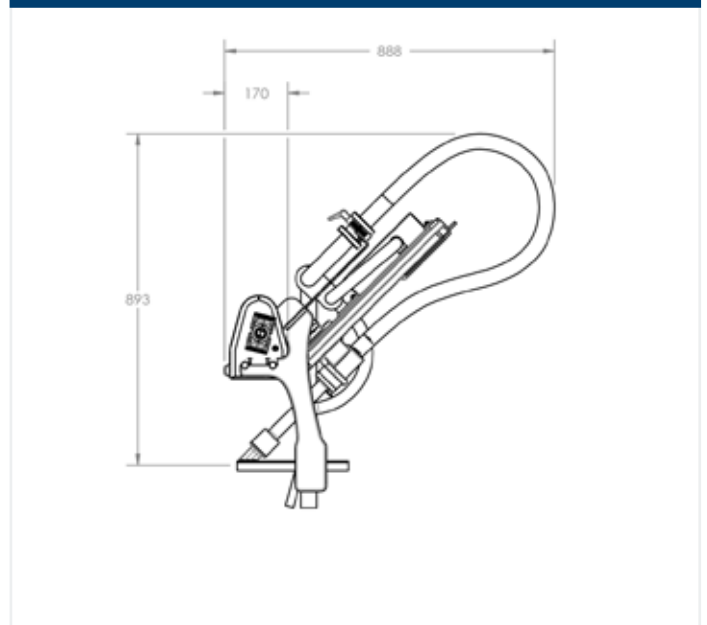

The figures above illustrate an example of a typical installation. OPTEL has a wide range of solutions to fit the particularities of your specific packaging lines. Contact us for details.

Other modules and options are also available. Contact your Regional Sales Representative for more information. Find the location closest to you at: optelgroup.com

NORTH AMERICA

OPTEL Canada — HEADQUARTERS
+1 418 688 0334

EUROPE

OPTEL Ireland
+353 61480965

ASIA

OPTEL India
+91 832 669 9600

SOUTH AMERICA

OPTEL Brazil
+55 19 3113 2570

optelgroup.com
© 2021 by OPTEL GROUP.
All rights reserved.

